

# Fieldbus and Industrial Ethernet solutions

## Drive's entry ticket for automation ecosystems



A wide variety of fieldbus and Industrial Ethernet systems are available on the market and all major protocols are supported by ABB drives, giving you the required flexibility, compatibility and security. So, no matter what preference you may have for communication networks and automation systems, we offer the correct solution to satisfy the specifications.

**ABB drives ensure connectivity to automation systems thanks to embedded Protocols and a wide range of F-series fieldbus interface modules, giving you a simplified interface to control and manage all ABB drives in low to medium voltage ranges.**

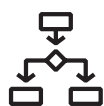

**Network connectivity of products** provides simplified interface for control and management of drives; improving quality, productivity, flexibility and scalability. Communication networks also offer a cost reduction in wiring costs, compared to traditional I/O connections. Combining these feature-rich adapter modules with ABB's drives offers a powerful drive solution to OEM's and system integrators.



### Advantages of ABB network connectivity

- Connectivity to virtually any automation architecture
- Fast and simple connectivity
- Products designed and tested to conform to protocol specifications
- Best in class support resources
- Ethernet/IP™ with ring topology DLR (Device Level Ring)
- Profinet IO with ring topology MRP (Media Redundancy Protocol)
- PROFINET S2 system redundancy



### Advantages of network connectivity

- Decreases mechanical and electrical installation time
- Reduces downtime
- More data is available at a lower cost
- Reduces time and cost of machine expansion or relocation
- Remote data access
- Diagnostics provide predictive failure warnings
- Open protocols, connectivity to any major PLC
- PC tool communication via installed PLC networks



### End user benefits

- Decrease in mechanical and electrical installation cost
- Decrease in down time
- Increase in productivity
- Diminished start-up cost
- Lower maintenance and diagnostic cost
- Quick access to network drives with PC based start-up and maintenance software tools



PROFINET® IO is an open standard for Industrial Ethernet and it is used from process automation to motion control, as well as for functional-safety solutions. The interface module supports PROFIdrive and ABB drive profiles and it is equipped with 2 RJ45 connections with an integrated switch that certified according to Conformance Class B (CC-B). It supports ring topology with Media Redundancy Protocol (MRP) and S2 system redundancy; PROFIsafe together with FSO-12/-21 for ACS880. FSPS-21 supports PROFIsafe over PROFINET for ACS380, ACS580 and ACS880.



EtherNet/IP™ is an industrial network protocol that adapts the Common Industrial Protocol (CIP) to standard Ethernet. It is one of the leading industrial protocols and it is widely used in a range of industries. The interface module acts as an EtherNet/IP™ server with support for ODVA AC/DC drive and ABB drive profiles. It supports both explicit messaging where each attribute of a class is set individually, and implicit messaging using input and output instances. It is equipped with 2 RJ45 connections with an integrated switch and support device-level ring (DLR). Add-On Instructions are available.



This is a Modbus® variant used for communications over TCP/IP networks. The interface module acts as a Modbus® TCP server with support for ABB drive profiles. Common read/write single- and multiple register function codes are supported. It is equipped with 2 RJ45 connections with an integrated switch.



EtherCAT® is a real-time Ethernet master/slave fieldbus system. The EtherCAT slave devices read the data addressed to them while the telegram passes through the device enabling fast real-time communication and the telegrams are only delayed by a few nanoseconds. Interface module supports CiA 402 and ABB drives profiles.



ETHERNET POWERLINK is a real-time protocol for standard Ethernet and the protocol guarantees transfer of time-critical data in very short cycles with configurable response time. Interface module supports CiA 402 and ABB drives profiles.



PROFIBUS® DP is the most widely used industrial network, ABB drives support PROFIBUS DP-V0 and DP-V1. Interface module supports PROFIdrive and ABB drives profiles.



CANopen® is a popular industrial communication network originally designed for motion-oriented machine control networks, such as handling systems. Interface module supports both cyclic and acyclic event driven communication. This makes it possible to reduce the bus load to a minimum and maintain short reaction times. It supports CiA 402 and ABB drive profiles.



DeviceNet™ offers robust, efficient data handling since it is based on a Produce/Consume model. Interface module uses CAN (Controller Area Network) as the backbone technology and defines an application layer to cover a range of device profiles. It supports ODVA AC/DC drive and ABB drives profiles.

Learn more from the fieldbus connectivity website:  
[new.abb.com/drives/connectivity/fieldbus-connectivity](http://new.abb.com/drives/connectivity/fieldbus-connectivity)



We reserve the right to make technical changes or modify the contents of this document without prior notice. With regard to purchase orders, the agreed particulars shall prevail. ABB does not accept any responsibility whatsoever for potential errors or possible lack of information in this document.

We reserve all rights in this document and in the subject matter and illustrations contained therein. Any reproduction, disclosure to third parties or utilization of its contents – in whole or in parts – is forbidden without prior written consent of ABB. Copyright© 2021 ABB. All rights reserved.

## Let's connect.

### ABB network communication adapters



The network adapter modules are flexible plug-in adapters that provide fast and simple universal connectivity to all major controllers. Universal connectivity means ABB low voltage drives connect to virtually all controller brands and communication networks, allowing users to choose the best network to meet their needs.

Network connectivity of products provides simplified interface for control and management of drives; improving quality, productivity, flexibility and scalability. Communication networks also offer a cost reduction in wiring costs, compared to traditional I/O connections.

Combining these feature-rich adapter modules with ABB's drives offers a powerful drive solution to OEMs and system integrators focused on the food & beverage, material handling, printing, rubber & plastics, and textile industries.

#### Advantages of Network Connectivity

- Decreases mechanical and electrical installation time
- Reduces down time
- More data is available at a lower cost
- Reduces time and cost of machine expansion or relocation
- Remote data access
- Diagnostics provide predictive failure warnings
- Open protocols, connectivity to any major PLC
- PC Tool communication via installed PLC networks

#### Advantages of ABB Network Connectivity

- Connectivity to virtually any automation architecture
- Fast & simple connectivity
- Products designed and tested to conform to protocol specifications
- Best in class support resources
- FENA-21 and FEIP-21 supports DLR (Device Level Ring)

#### End User Benefits

- Decrease in mechanical and electrical installation cost
- Decrease in down time
- Increase in productivity
- Diminished start-up cost
- Lower maintenance and diagnostic cost
- Quick access to networked drives with PC-based start-up and maintenance software tools

Protocol	Network Adapters	Maximum Devices	Baud Rate
CANopen®	FCAN-01	127	50 kbit/s - 1 Mbit/s
ControlNet™	FCNA-01	48 Node, 250 m	5 Mbit/s
DeviceNet™	FDNA-01	64	125 kbit/s - 500 kbit/s
EtherCAT®	FECA-01	65535	100 Mbit/s
EtherNet/IP™	FENA-01/-21 FEIP-21	Nearly Unlimited	10 / 100 Mbit/s
EtherNet™ POWERLINK	FEPL-02	240	100 Mbit/s
Modbus® RTU	FMBA-01 FSCA-01 FRSA-00	247	600 bit/s - 115.2 kbit/s
Modbus® TCP	FENA-01 FMBT-21	Nearly Unlimited	10 / 100 Mbit/s
PROFIBUS® DP	FPBA-01	32/segment, 126 total	9.6 kbit/s - 12 Mbit/s
PROFINET® IO	FENA-01/-21	Nearly Unlimited	10 / 100MB Full/Half Duplex
	FPNO-21	Nearly Unlimited	10 / 100 Mbit/s

**CANopen: FCAN-01 (+K457)**

The adapter module fulfils CiA (CAN in Automation) standard DSP 402 (Device Profile Drives and Motion Control). CANopen device profiles define both direct access to the drive parameters and time critical process data communication.

**ControlNet: FCNA-01 (+K462)**

The adapter supports redundant RG-6 quad shielded cable (coax) for the bus connection and is compatible with all master stations that support the ControlNet protocol. The module is also equipped with a NAP (Network Access Port). FCNA-01 control is based on the standard ControlNet objects and vendor specific objects.

**DeviceNet: FDNA-01 (+K451)**

The DeviceNet adapter module acts as a Class 2 slave with predefined master-slave connection set services. These include the Explicit Messaging, the Poll-Response service and the Change of State/Cyclic service. The adapter supports the ODVA AC/DC Drive Functional Profile with additional features and ABB drives profile.

**EtherCAT: FECA-01 (+K469)**

The adapter module supports the CANopen DSP 402 (Device Profile Drives and Motion Control) profile or the ABB drives profile. The FECA-01 implements the EtherCAT state machine, four sync manager channels to control the access to the application memory, two watch dogs and specified EtherCAT® services, addressing modes and FMMUs.

**EtherNet/IP: FENA-01 (+K466) / FENA-21 (+K475) / FEIP-21 (+K490)**

The adapter module acts as an EtherNet/IP server with support for ODVA AC/DC Drive, ABB drives and Transparent profiles. The adapter module supports both explicit messaging where each attribute of a class is set individually and implicit messaging using input and output instances. The FENA-21 supports DLR (Device Level Ring).

**EtherNet PowerLink: FEPL-02 (+K470)**

Ethernet PowerLink is a communication profile for real-time Ethernet communication. The FEPL-02 module supports CiA 402 and the ABB Drives profile. In addition, two transparent modes - for 16-bit and 32-bit words respectively - are available.

**Modbus-RTU: FMBA-01 (+K458) / FSCA-01 / FRSA-00**

The adapter module enables the connection of the drive to a RS-485 Modbus-RTU network. Common read/write single and multiple register function codes are supported.

FRSA-00 is a set of 20 adapters.

**Modbus-TCP: FENA-01 (+K466) / FENA-21 (+K475) / FMBT-21 (+K491)**

The adapter module acts as a Modbus/ TCP server with support for ABB drives and Transparent profiles. Common read/write single and multiple register function codes are supported.

**PROFIBUS DP: FPBA-01 (+K454)**

The adapter module supports PROFIBUS DP-V0 and DP-V1 communication. The FPBA-01 automatically detects the telegram type used, and supports both PPO messages 1 to 6 and standard telegrams (STD) 1 and 20. Communication profiles: PROFIdrive, ABB drives, Transparent 16 and Transparent 32 are supported.

**PROFINET IO: FENA-01 (+K466) / FENA-21 (+K475) / FPNO-21 (+K492)**

PROFINET IO is a fieldbus protocol that enables communication between programmable controllers and distributed field devices in an Ethernet network. The adapter module acts as a ProfiNet I/O device with support for PROFIdrive, ABB Drives, Transparent 16-bit, Transparent 32-bit profiles, and PROFIdrive positioning mode for ACSM1 Drives. The standard UDP/IP and TCP/IP channel is used for parameterization and configuration of devices and for acyclic operations. The real time (RT) channel is used for cyclic data transfer and alarms. The isochronous real time (IRT) channel is not supported.

Protocol	Network adapter*	Plus code	ACS355	ACS880	ACS380	ACX580	ACX480
CANopen	FCAN-01	+K457	X	X	X	X	—
ControlNet	FCNA-01	+K462	X	X	—	X	—
DeviceNet	FDNA-01	+K451	X	X	X	X	—
EtherCAT	FECA-01	+K469	—	X	X	X	—
	FENA-01	+K466	X	—	—	—	—
EtherNet/IP	FENA-21	+K475	X	X	X	X	—
	FEIP-21	+K490	—	X	X	X	X
POWERLINK	FEPL-02	+K470	—	X	X	X	—
	embedded	—	—	X	X**	X	—
Modbus-RTU	FMBA-01	+K458	X	—	—	—	—
	FSCA-01	—	—	X	—	X	—
	FRSA-00	—	X	—	—	—	—
Modbus-TCP	FENA-01	+K466	X	—	—	—	—
	FENA-21	+K475	X	X	X	X	—
	FMBT-21	+K491	—	X	X	X	X
Profibus-DP	FPBA-01	+K454	X	X	X	X	—
	FENA-01	+K466	X	—	—	—	—
PROFINET IO	FENA-21	+K475	X	X	X	X	—
	FPNO-21	+K492	—	X	X	X	X

\* also known as fieldbus

\*\*embedded on BMIO-01 installed on Standard ACS380-040S drive

# FECA-01 EtherCAT® adapter module

## Quick installation and start-up guide

### Safety instructions



**WARNING!** Obey the safety instructions of the drive. If you ignore them, injury or death, or damage to the equipment can occur.

### Mechanical installation

1. Pull out the lock.
2. Install the module carefully to an option module slot of the drive. See the drive hardware manual.
3. Push in the lock.
4. Tighten the screw to torque 0.8 N·m using a Torx TX10 screwdriver.

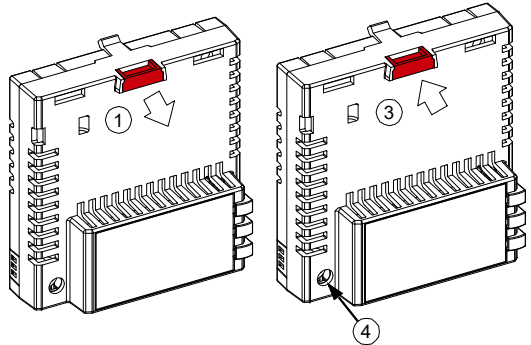

**WARNING!** Do not use excessive force, or leave the screw too loose. Over-tightening can damage the screw or module. A loose screw decreases the EMC performance, and can cause an operation failure.

### Electrical installation

#### Layout of the module

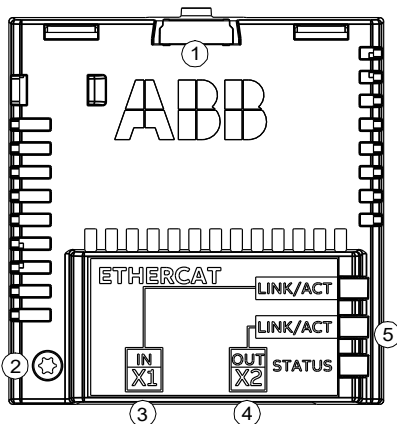

No.	Description
1	Lock
2	Mounting and grounding screw
3	RJ-45 connector [X1 IN]
4	RJ-45 connector [X2 OUT]
5	Diagnostic LEDs

## ■ Connection procedure

1. Connect the network cables to connectors [X1 IN] and [X2 OUT] on the module.
2. Connect the cable from the EtherCAT master to the left port [X1 IN].
3. In the line topology, if there are more slave devices in the same line, connect the next slave device to the right port [X2 OUT].

## Start-up

To control the drive with the adapter module, set at least the basic parameters listed in the table below. For full parameter descriptions, refer to the adapter module's user manual or to the drive's firmware manual.

## ■ Basic parameter settings

Index	Name	Value
20.01	Ext1 commands	Fieldbus A
22.11	Speed ref1 source	FBA A ref 1
28.11	Frequency ref1 source	FBA A ref 1
50.01	FBA A enable	Enable (or select the option slot in which the module is installed).
50.02	FBA A comm loss func	Fault
51.02	Profile	The CANopen device profile (CiA 402) is the default value.

To take the settings into use, validate and refresh the parameters with parameter 51.27 FBA par refresh.

## Further information

See the latest version of FECA-01 EtherCAT<sup>®</sup> adapter module user's manual (3AUA0000068940 [English]) in ABB library ([www.abb.com/drives/documents](http://www.abb.com/drives/documents)).



FECA-01 manual

For more information on ABB fieldbus options and protocols, see the fieldbus communications web page ([new.abb.com/drives/connectivity/fieldbus-connectivity](http://new.abb.com/drives/connectivity/fieldbus-connectivity)).



Fieldbus communications web page

[abb.com/drives](http://abb.com/drives)

© Copyright 2023 ABB. All rights reserved.  
Specifications subject to change without notice.



3AXD50000158553B

